

© 2006 (Edition)
AAT Alber Antriebstechnik GmbH

Benennung: Trägerprofil komplett
Zeichnungsnummer: Q1601 A

149mm	310 329
166mm	310 064
204mm	310 551
226mm	310 065
286mm	310 066
346mm	310 109

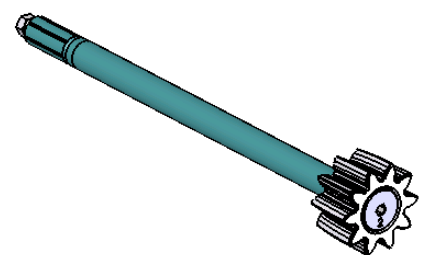

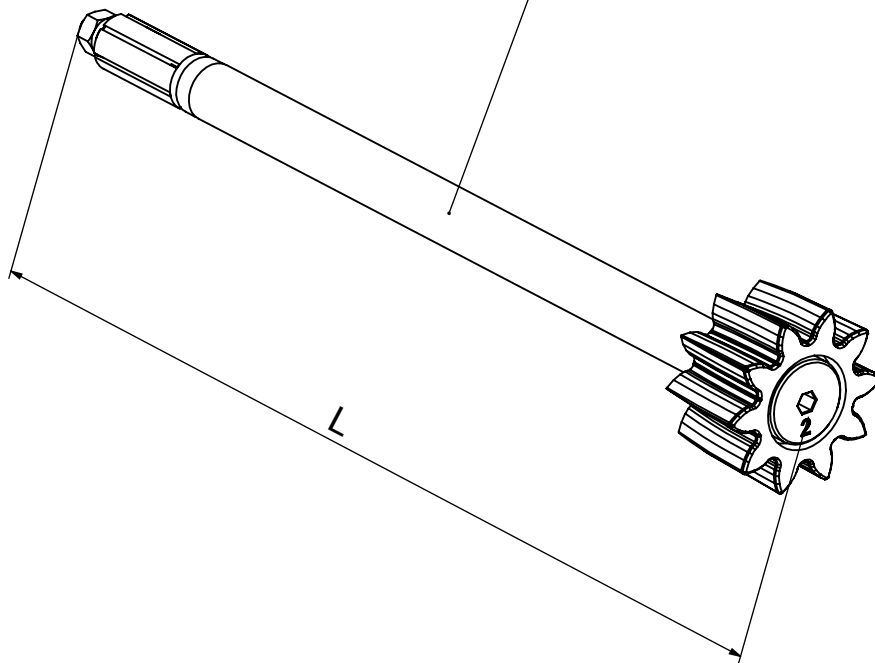
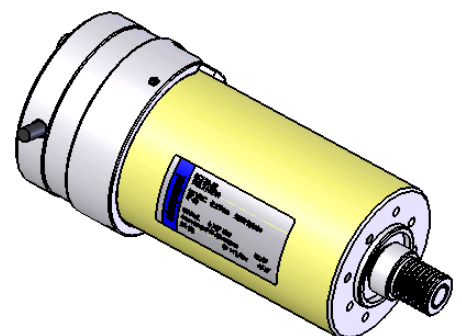
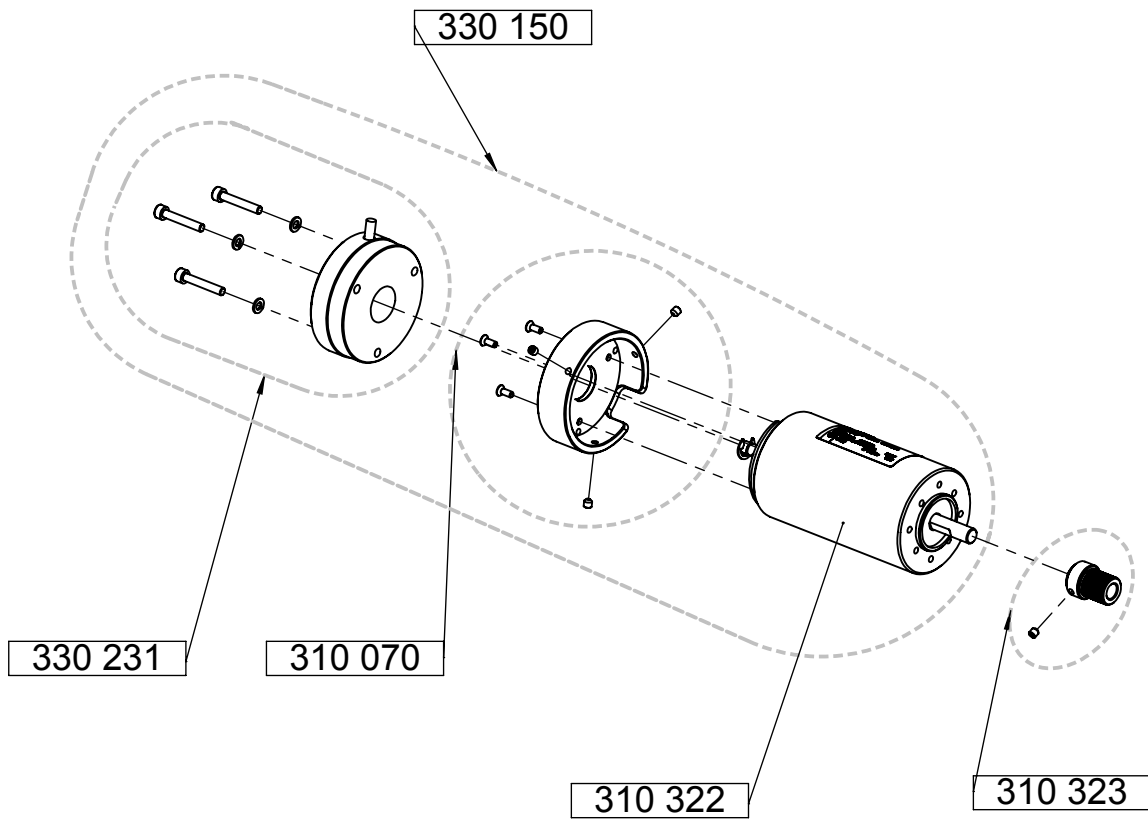

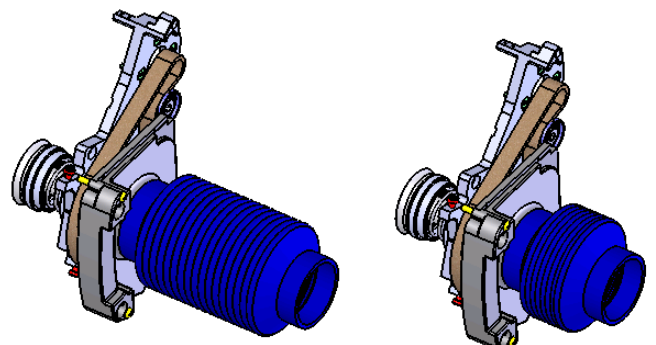
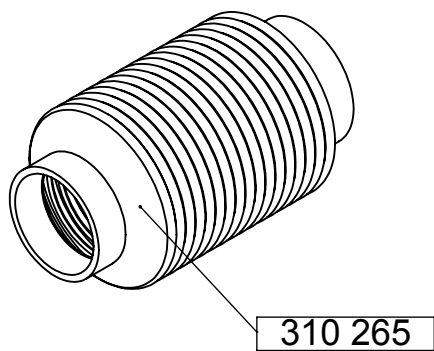
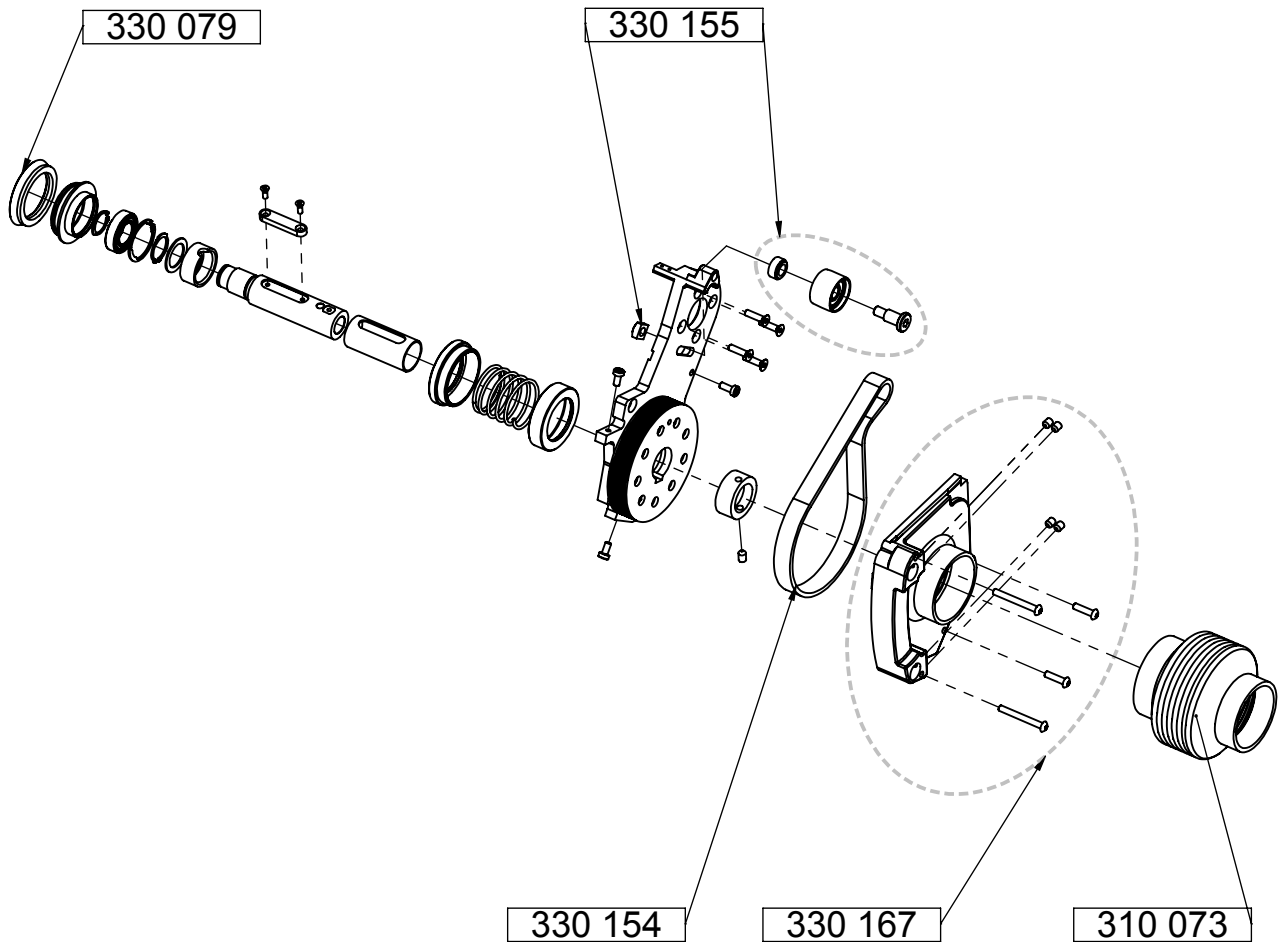

© 2010 (Edition)
AAT Alber Antriebstechnik GmbH

Benennung: Motorstellplatte kpl.
Zeichnungsnummer: Q1602_F
Revision: 1

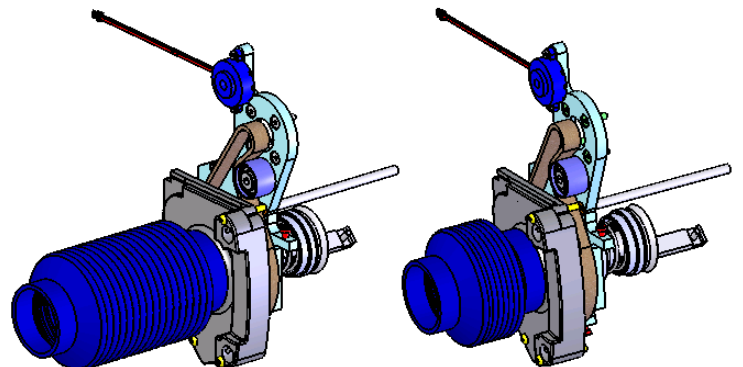
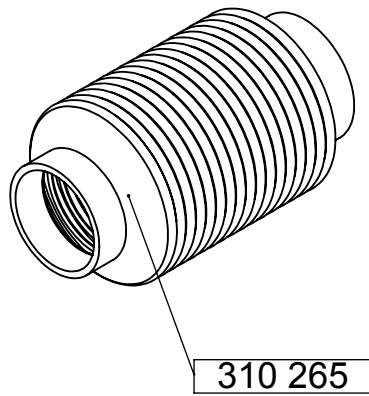
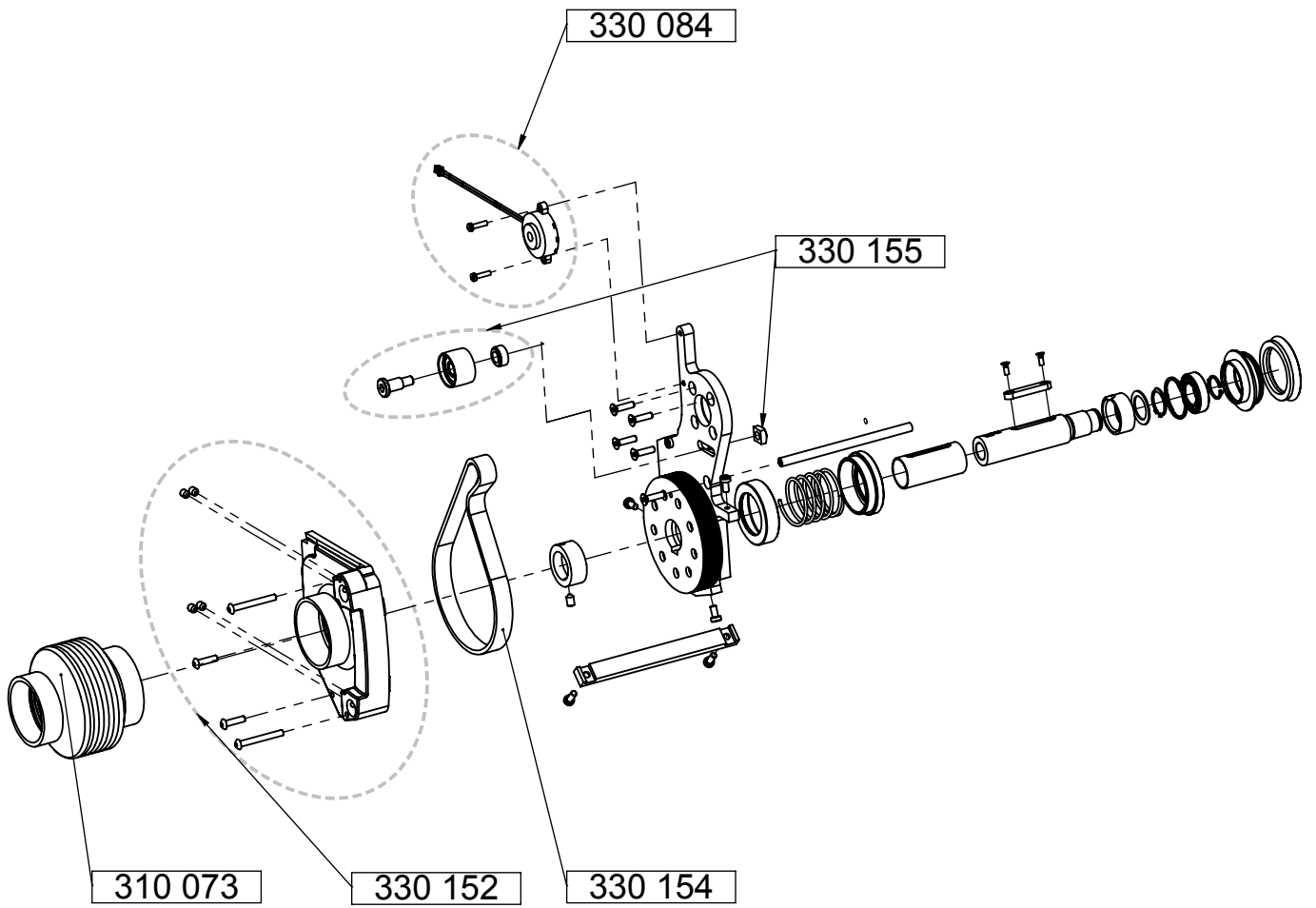

© 2010 (Edition)
AAT Alber Antriebstechnik GmbH

Benennung: Motorstellplatte kpl.
Zeichnungsnummer: Q1602_G
Revision: 1

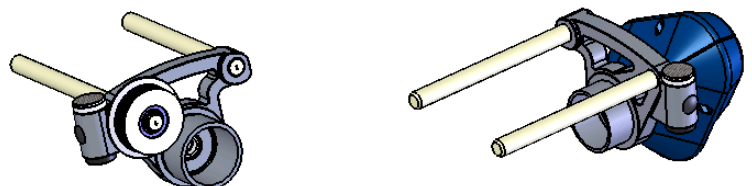
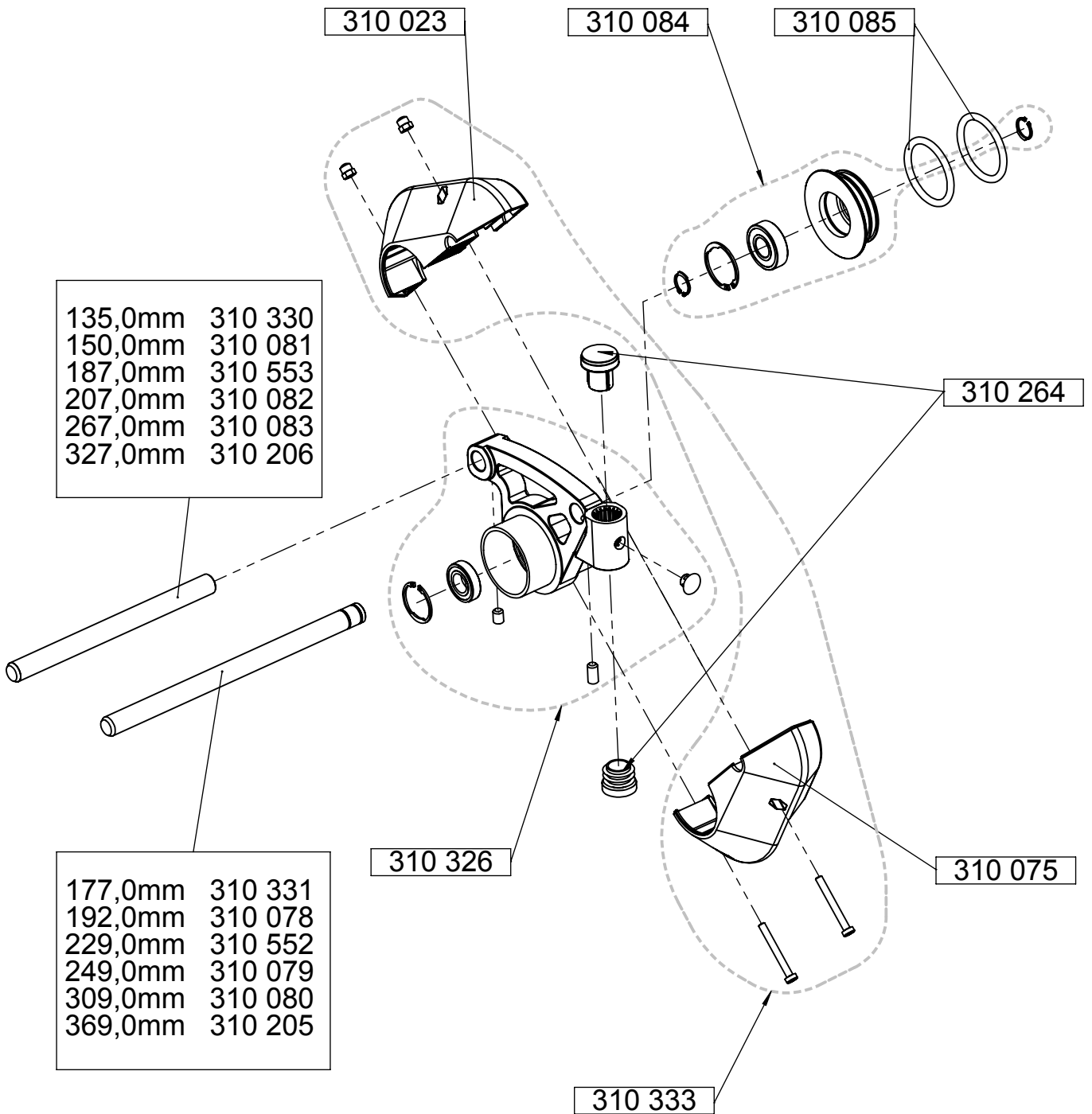

135,0mm	310 330
150,0mm	310 081
187,0mm	310 553
207,0mm	310 082
267,0mm	310 083
327,0mm	310 206

177,0mm	310 331
192,0mm	310 078
229,0mm	310 552
249,0mm	310 079
309,0mm	310 080
369,0mm	310 205

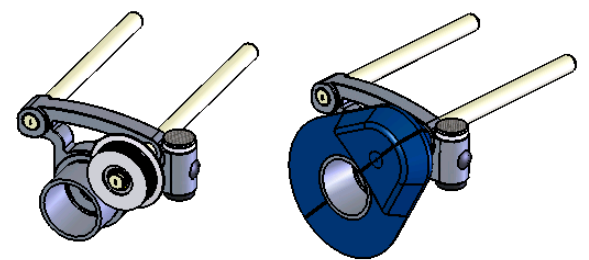
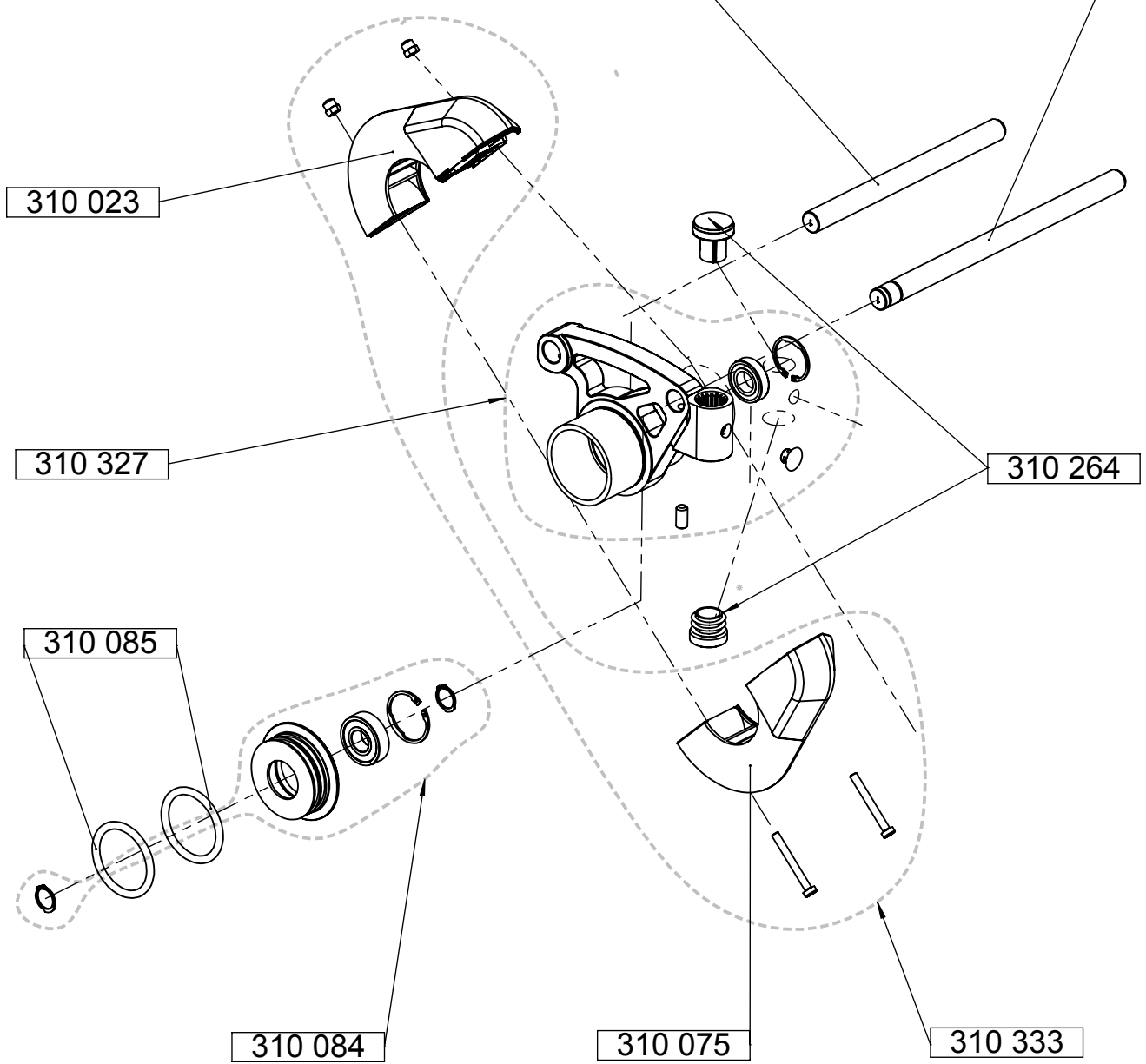

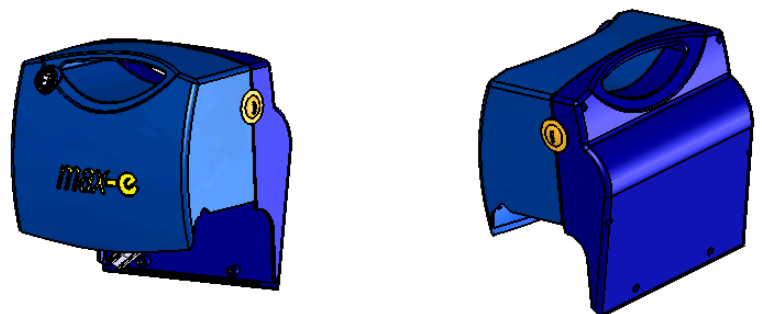
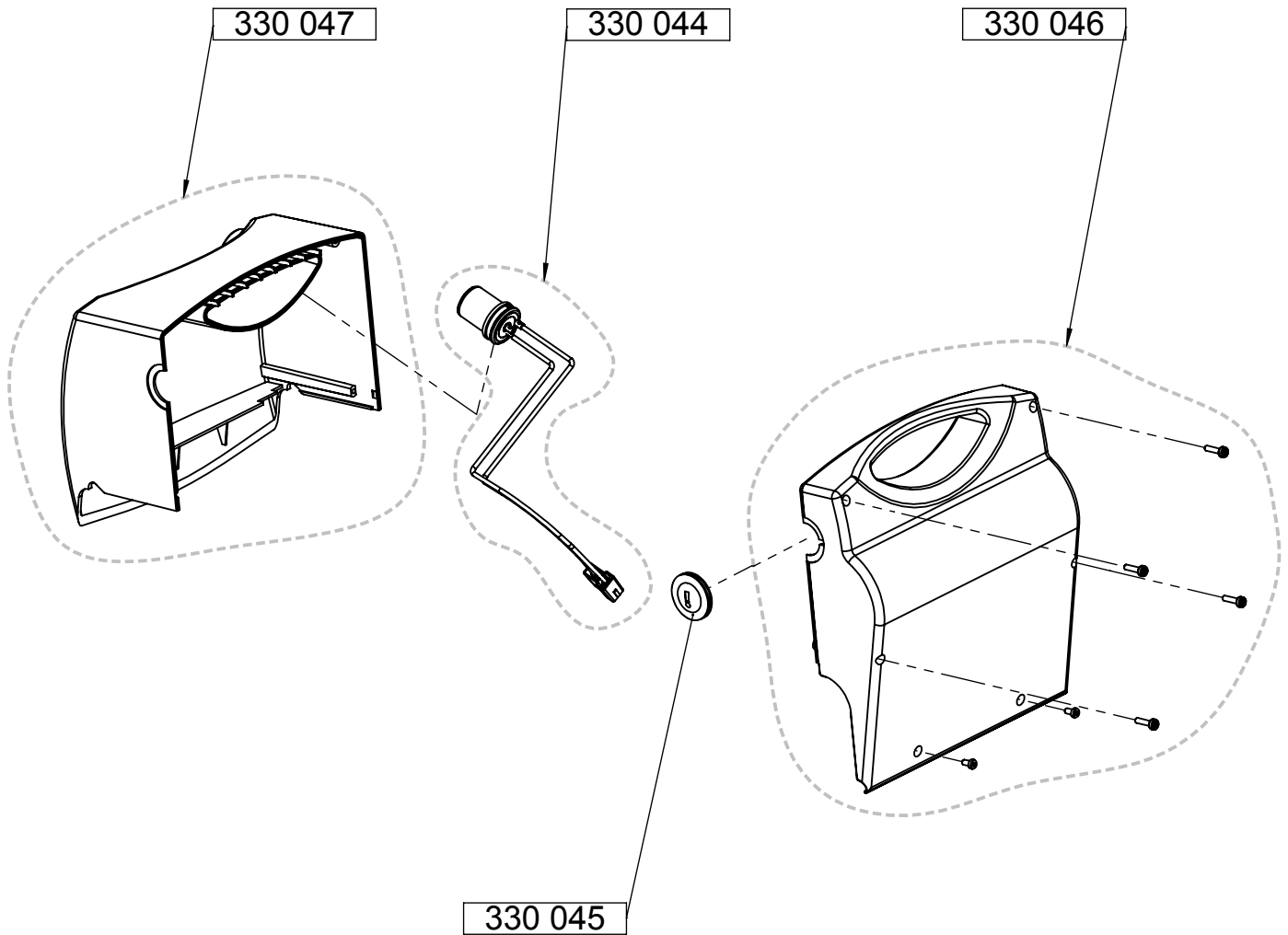

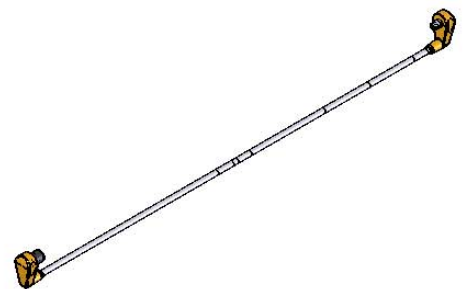
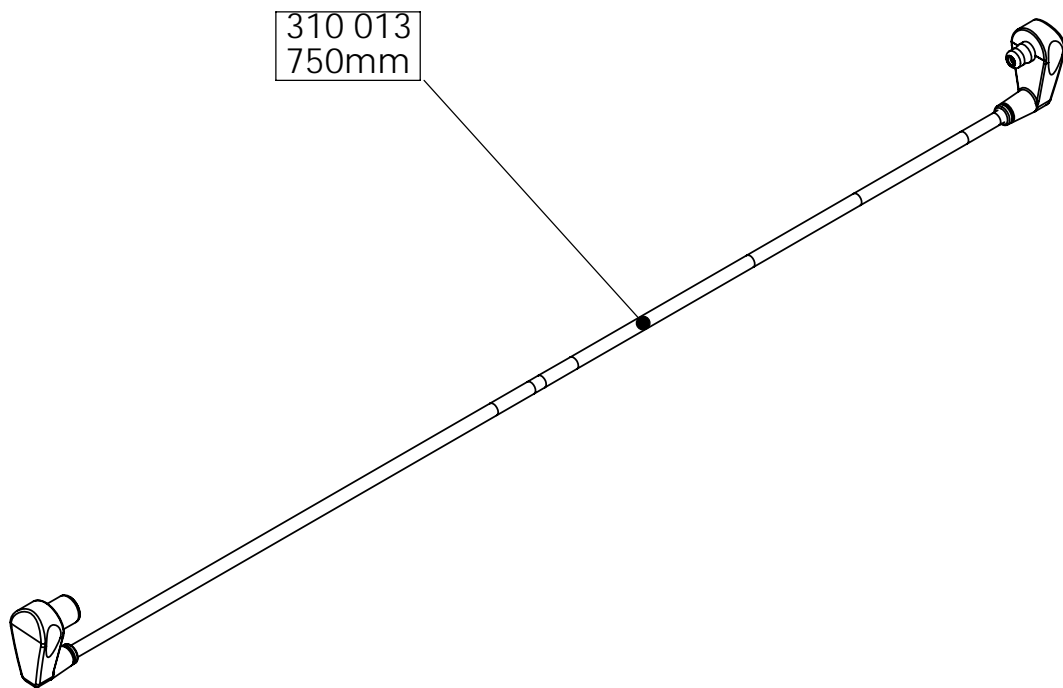

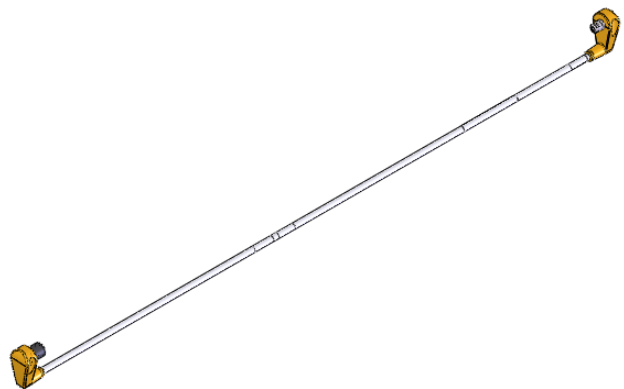
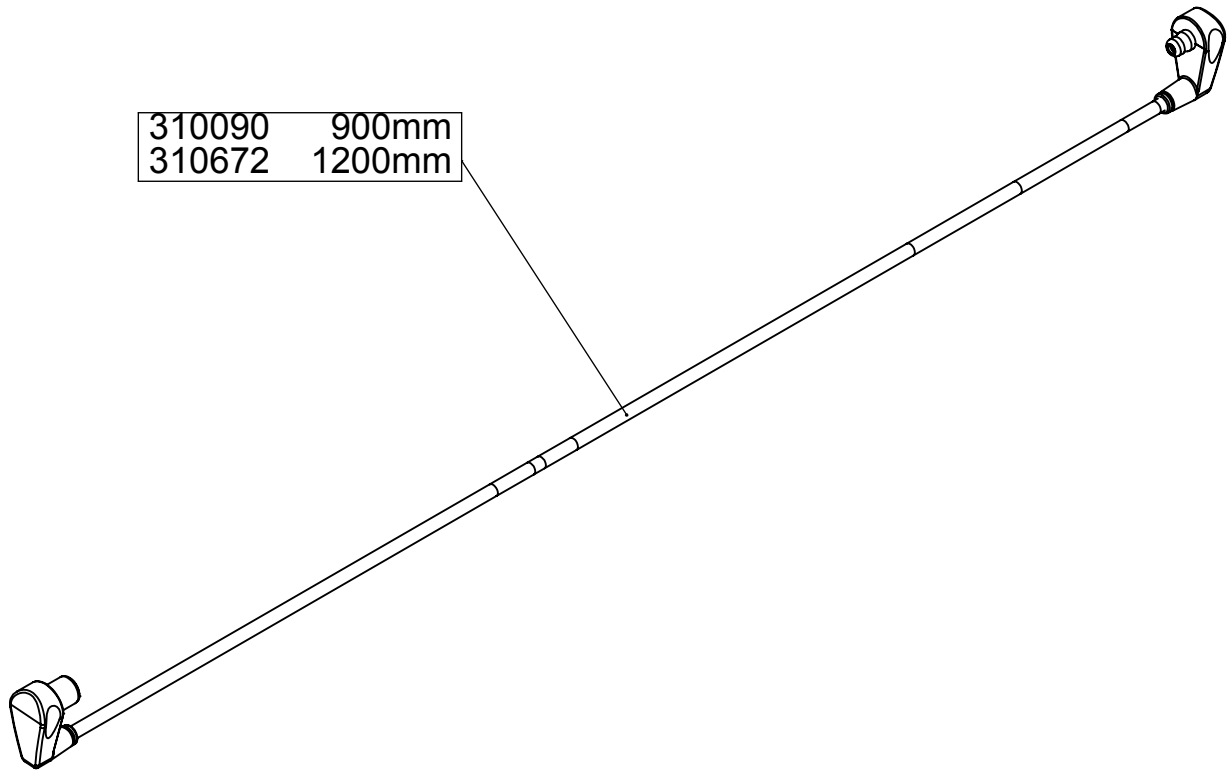

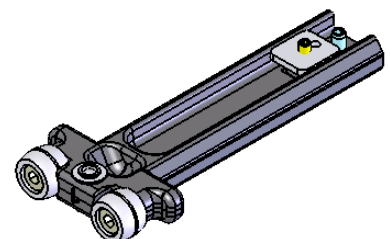
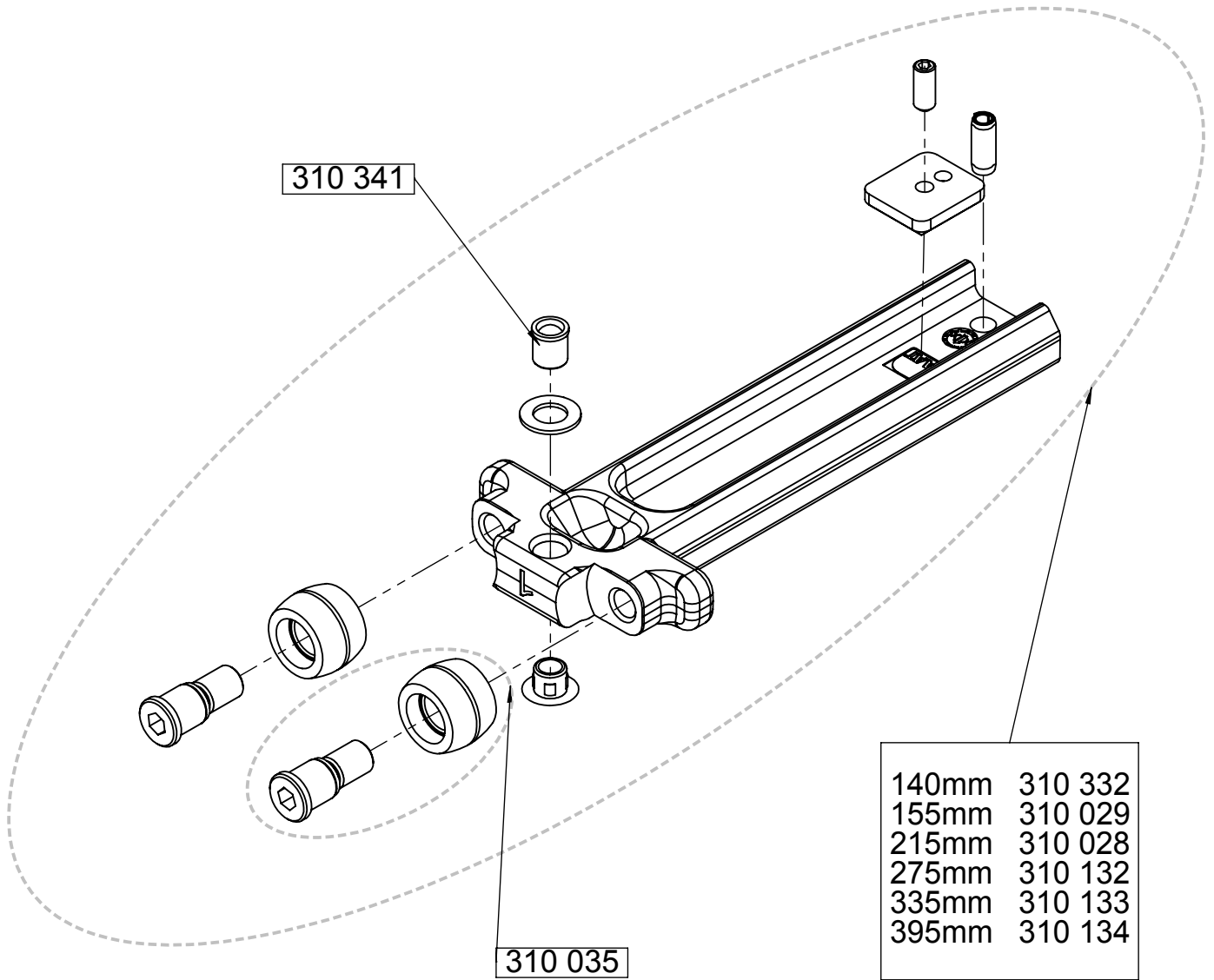

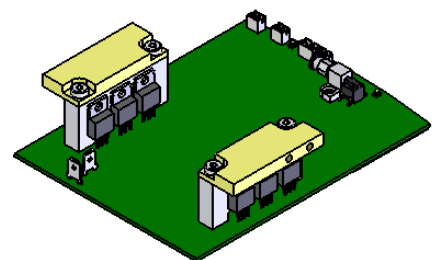
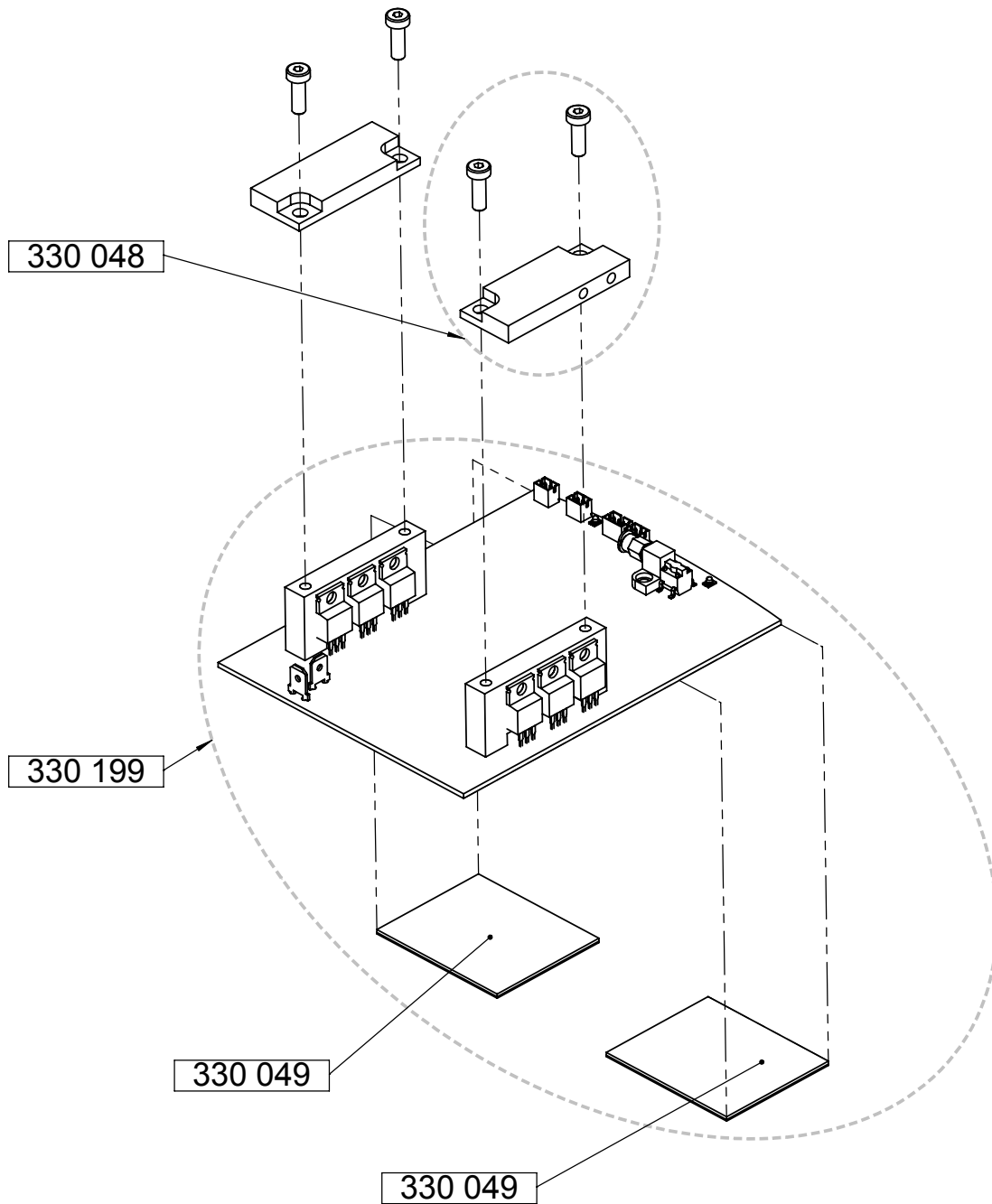

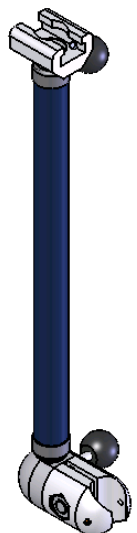
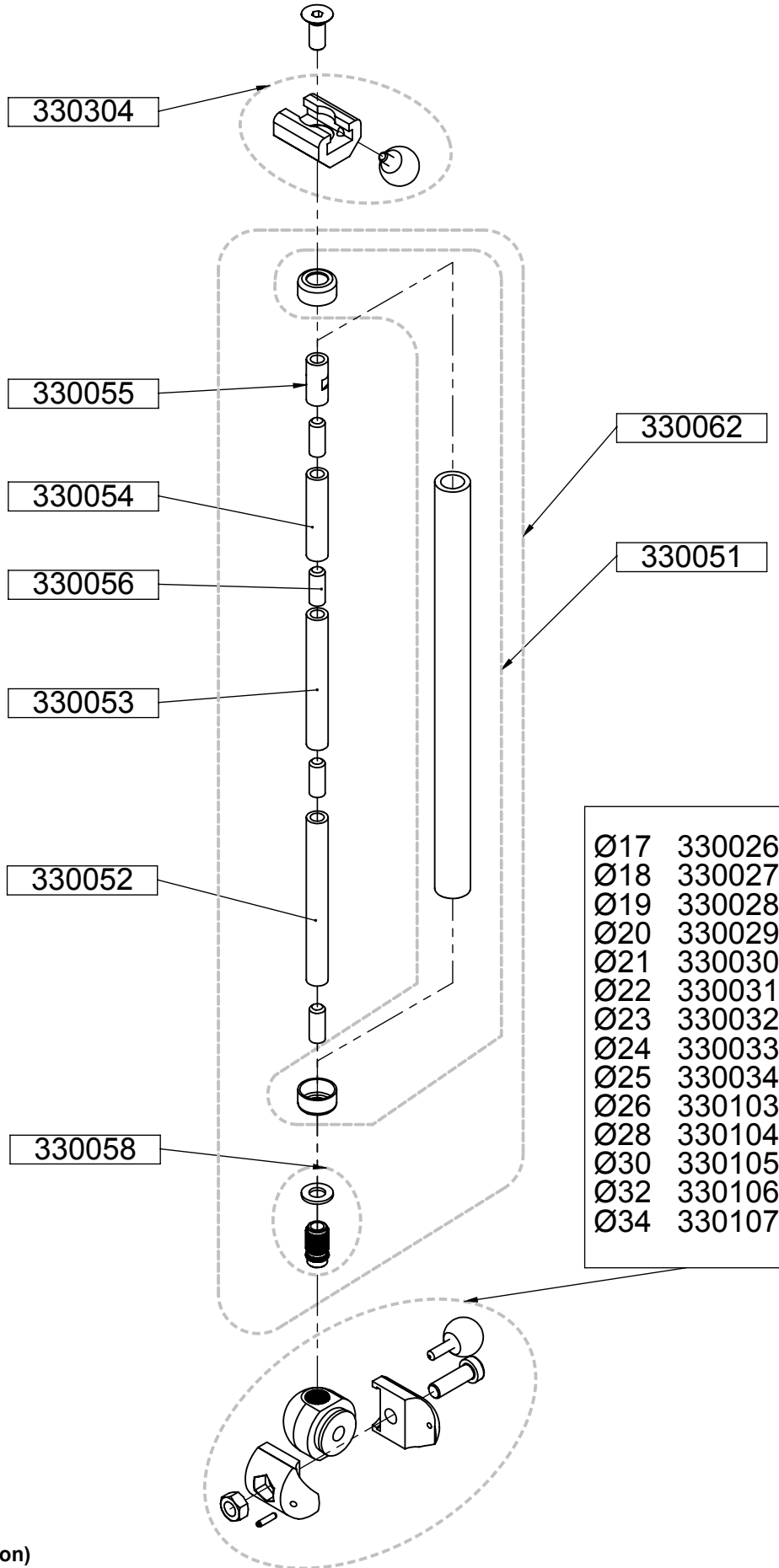

V1.1

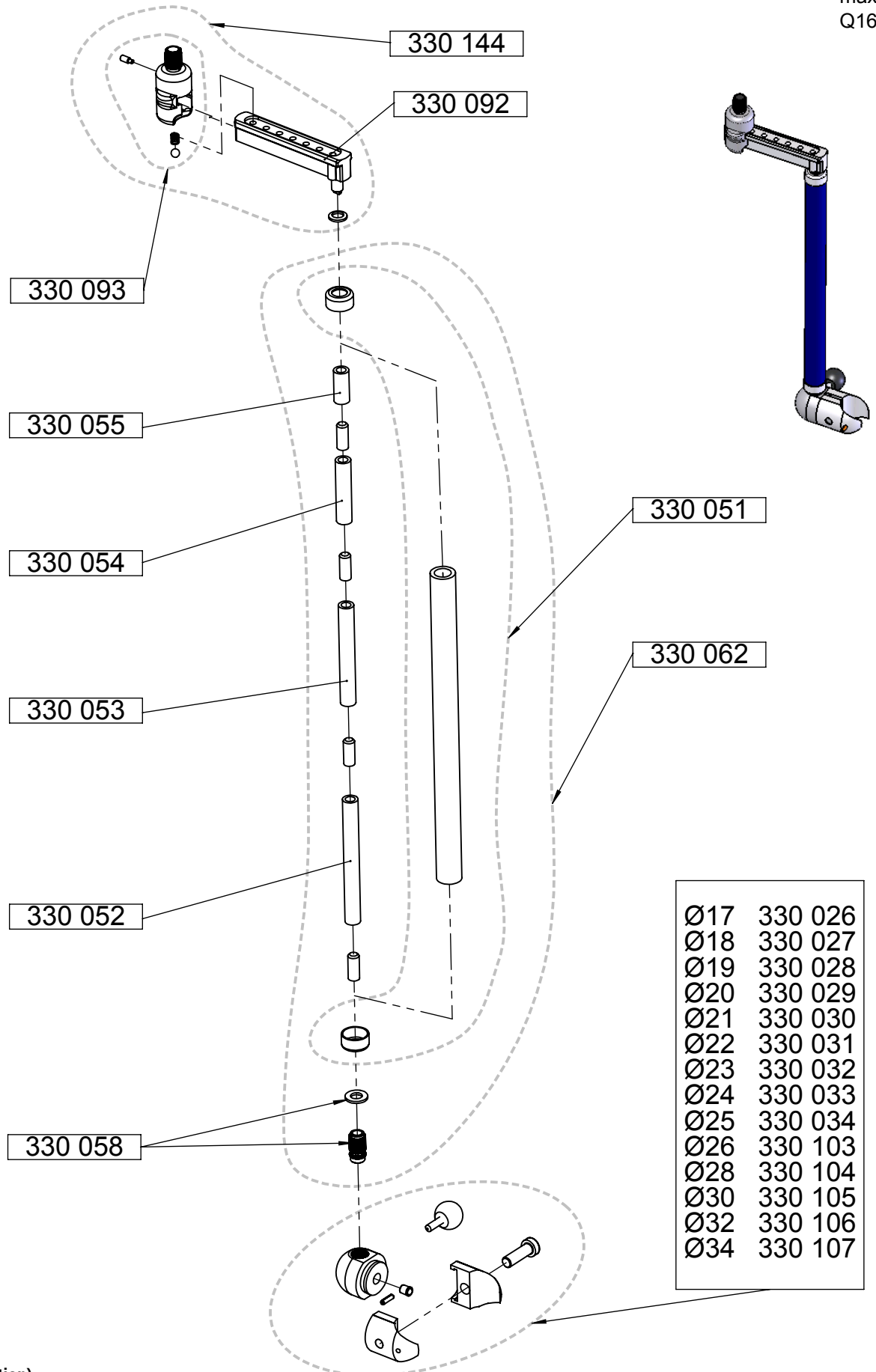

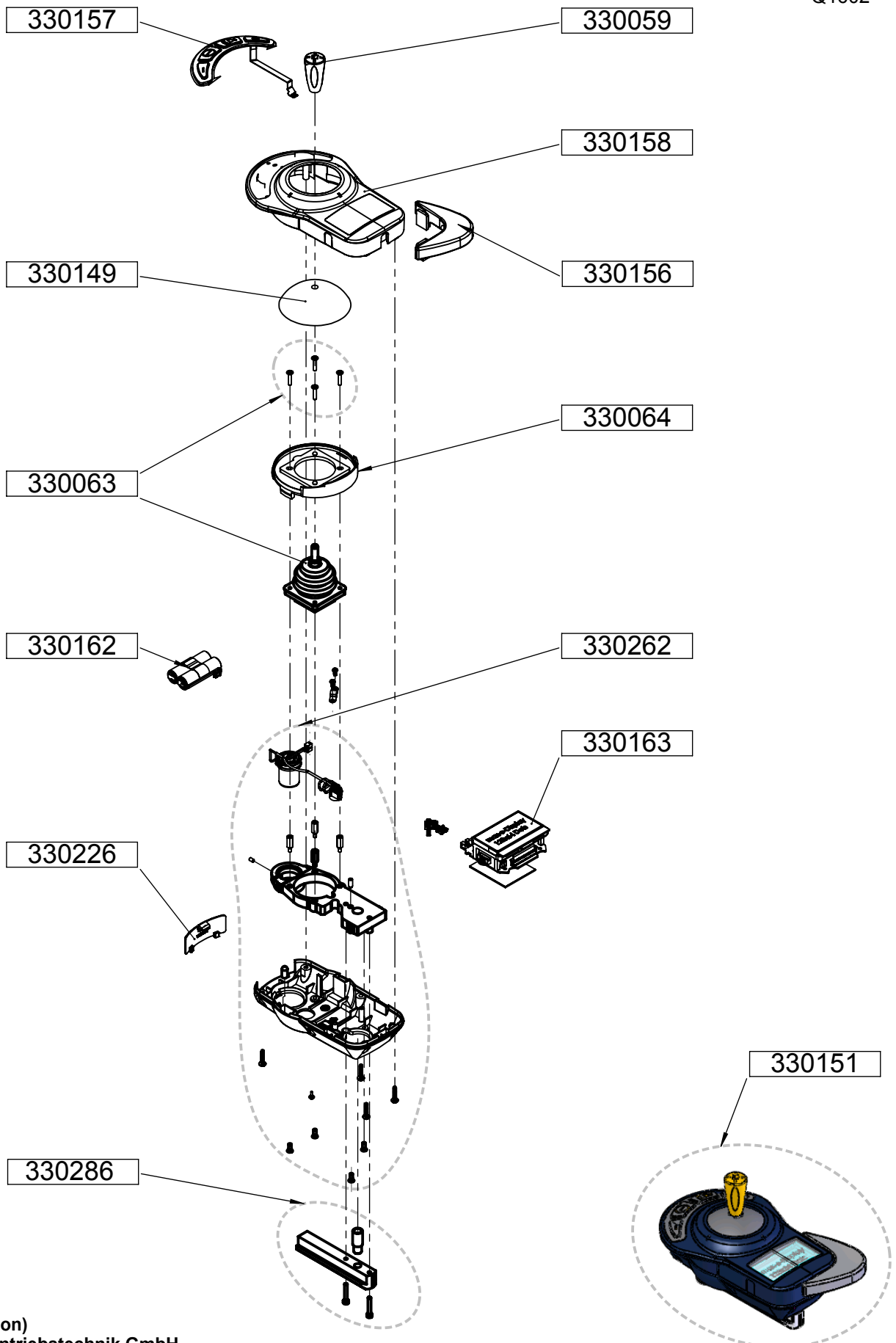

V1.1

max-e
Q1602

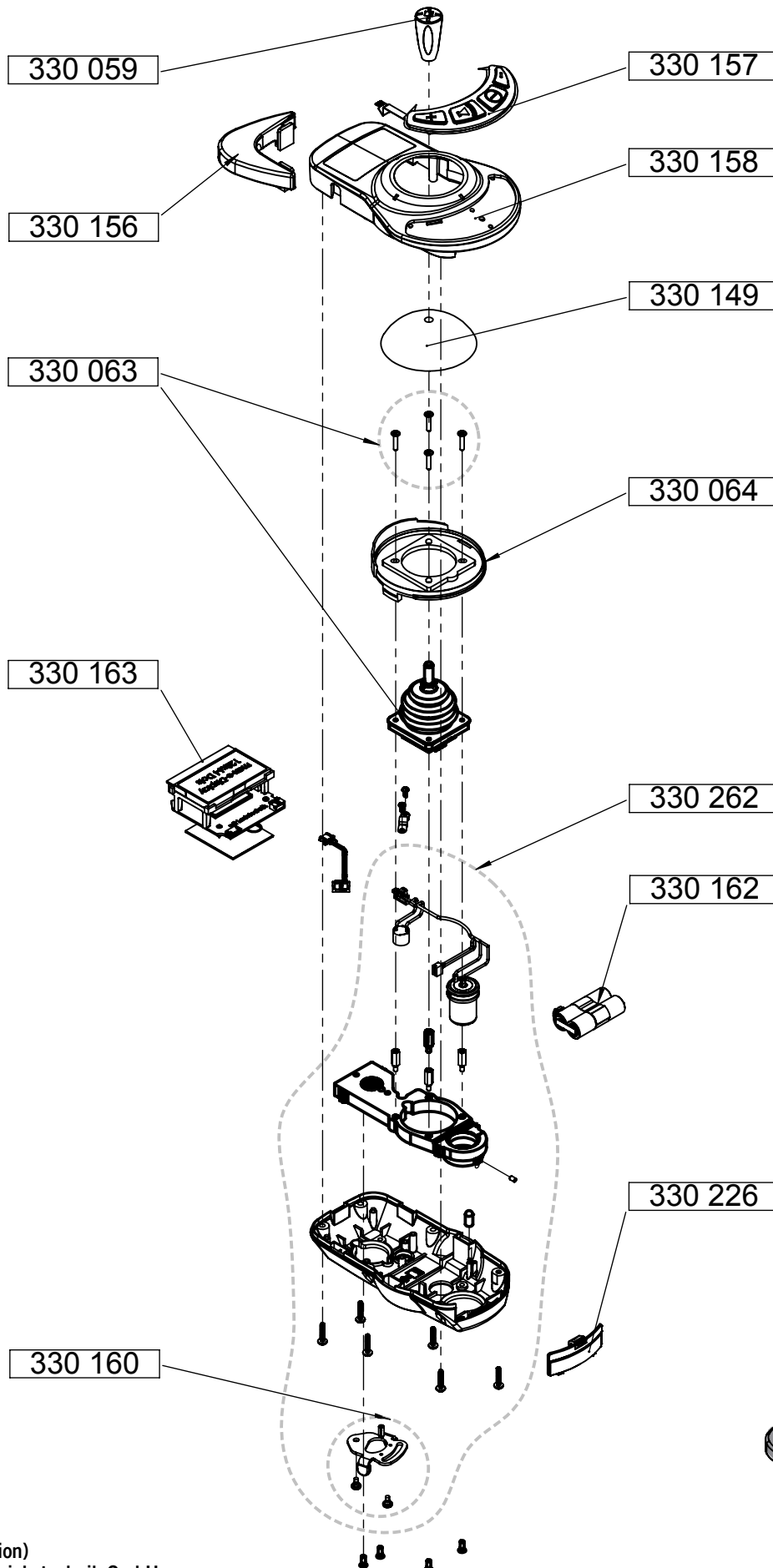

© 2011 (Edition)
AAT Alber Antriebstechnik GmbH

Benennung: Bedienteil
Zeichnungsnummer: Q1602_P_1
Revision: 3

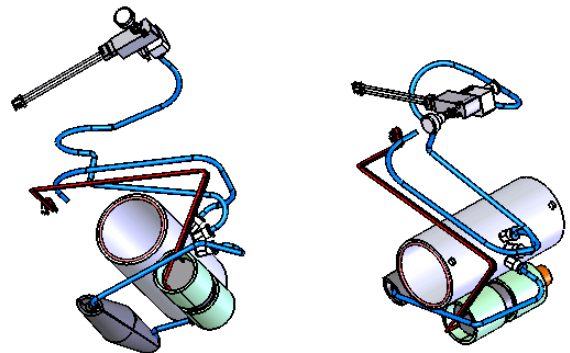
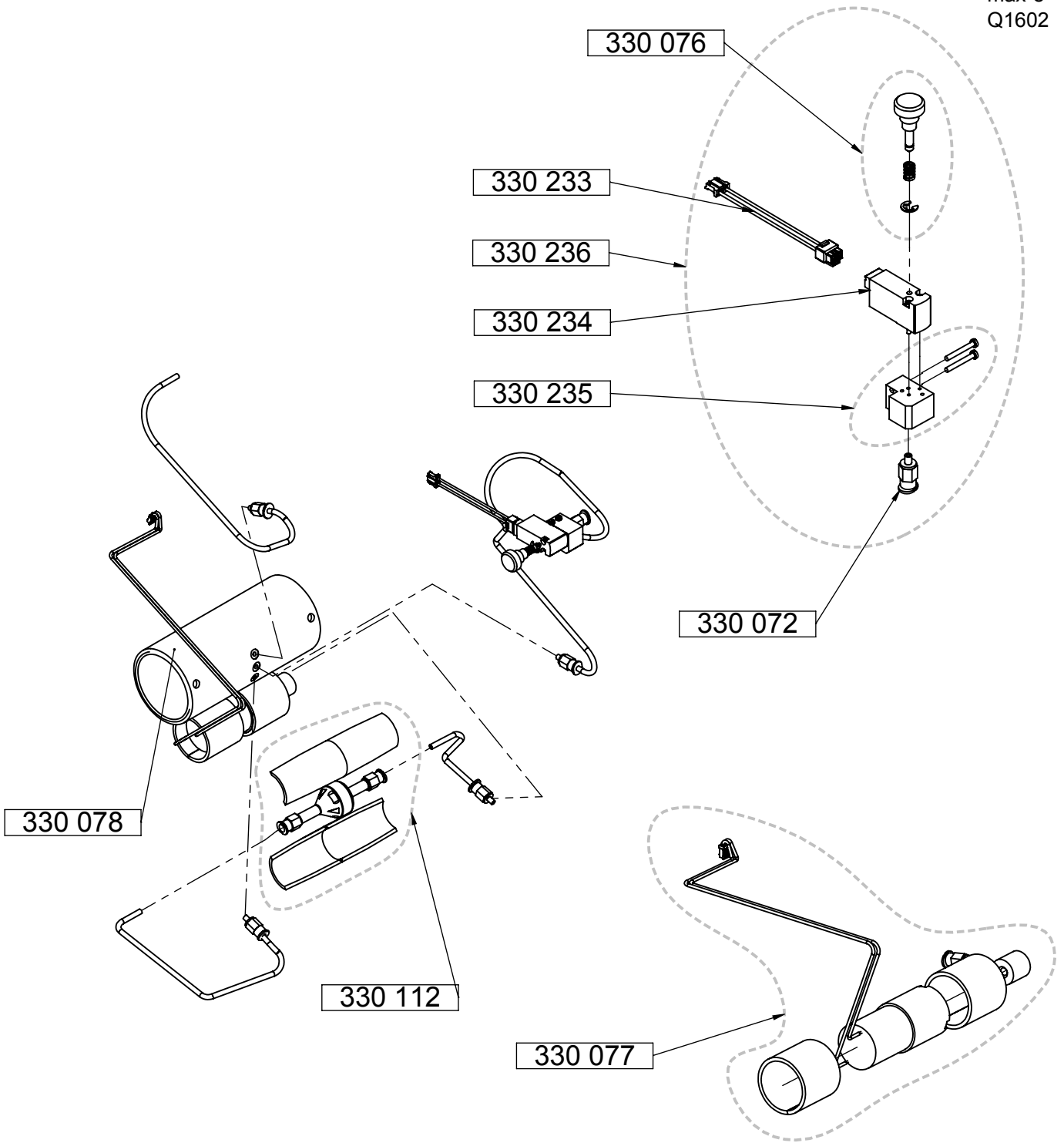

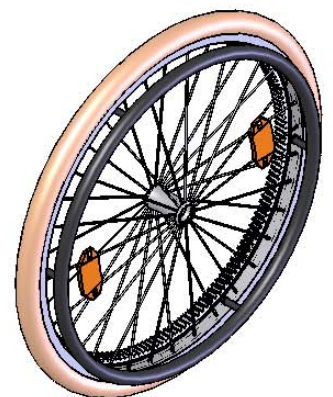
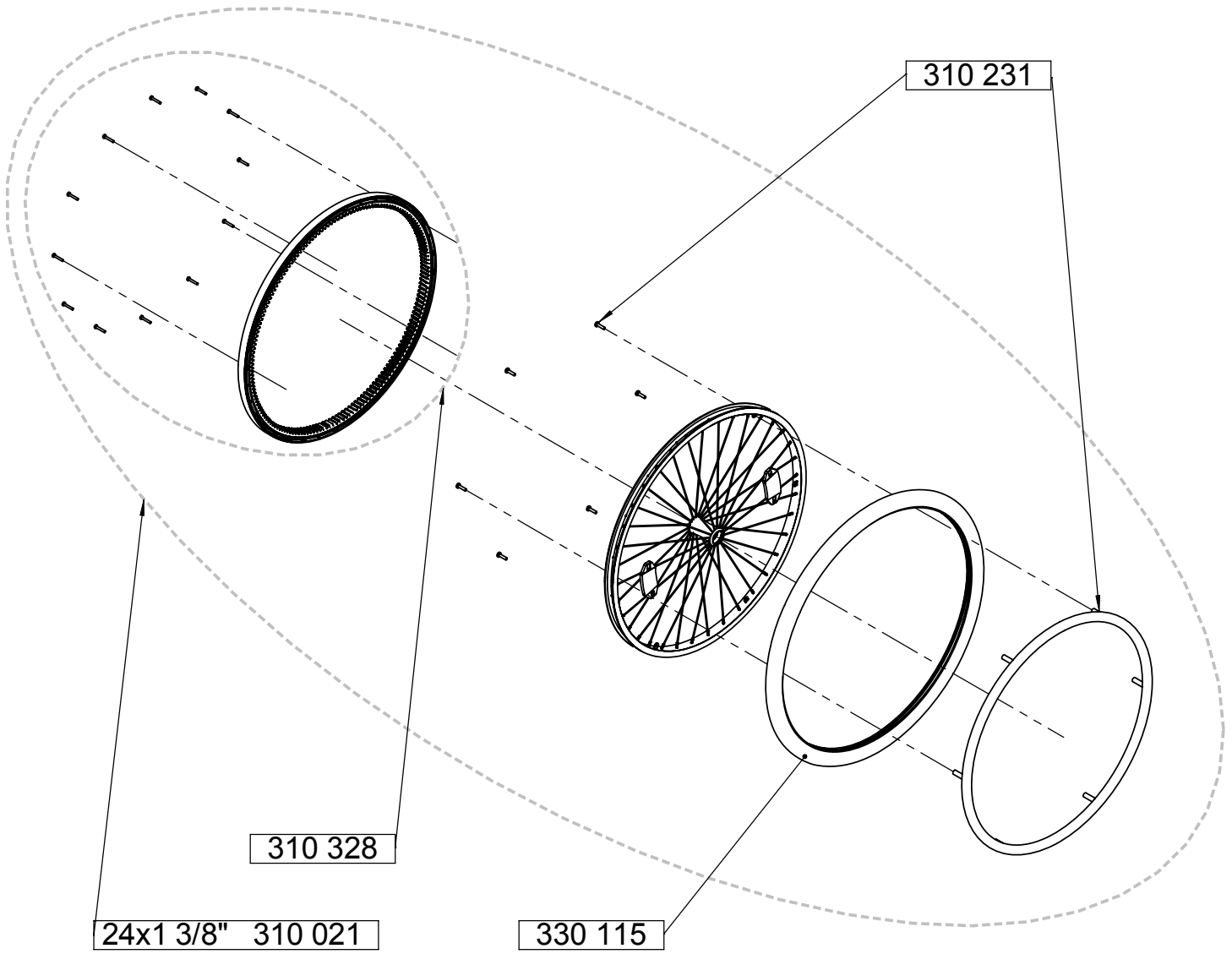

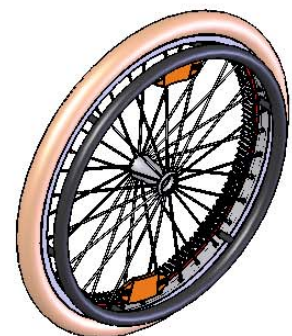
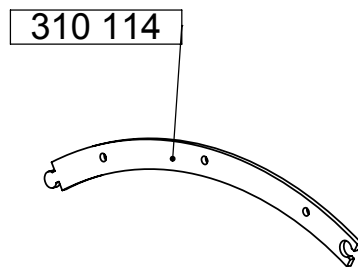
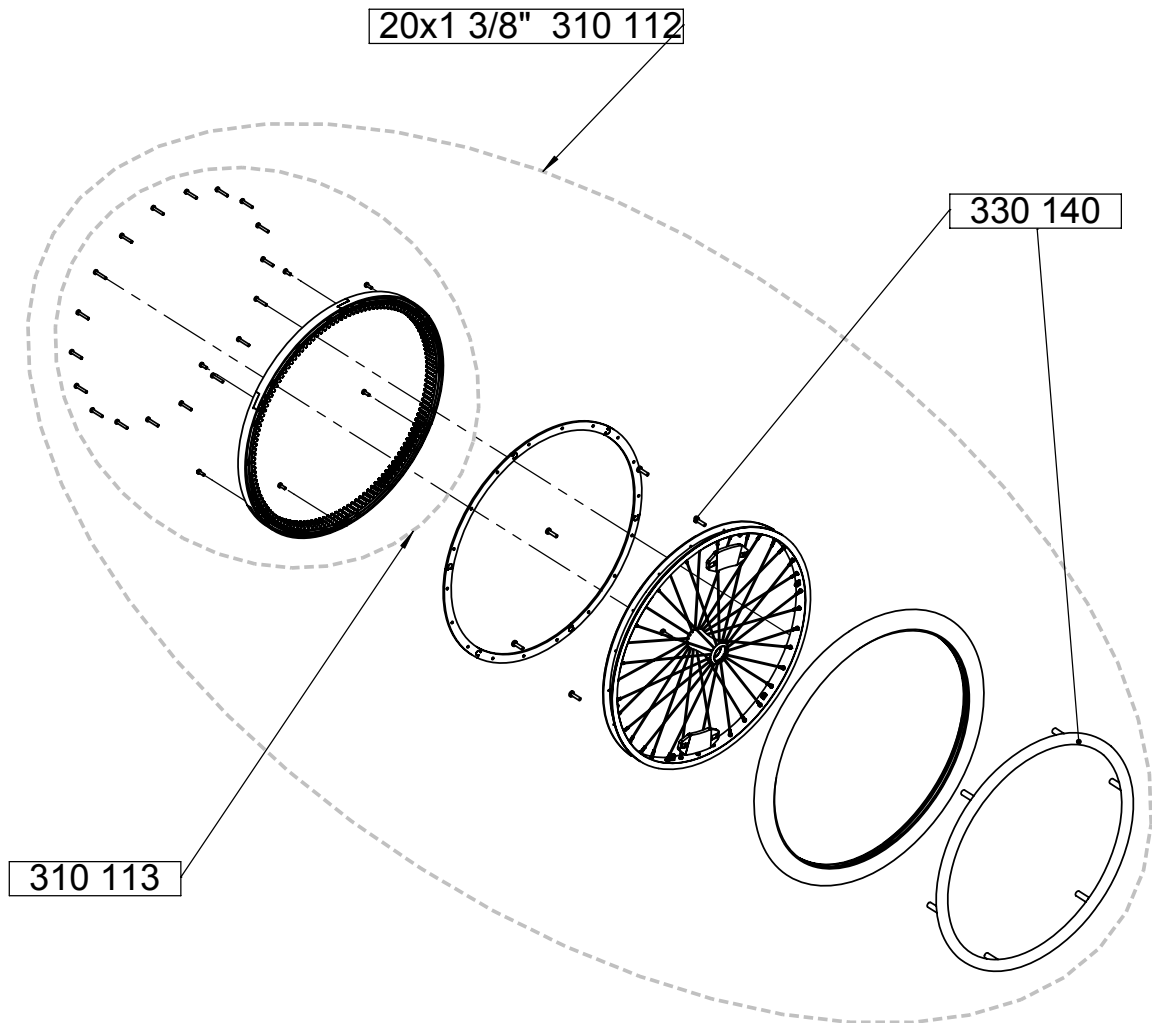

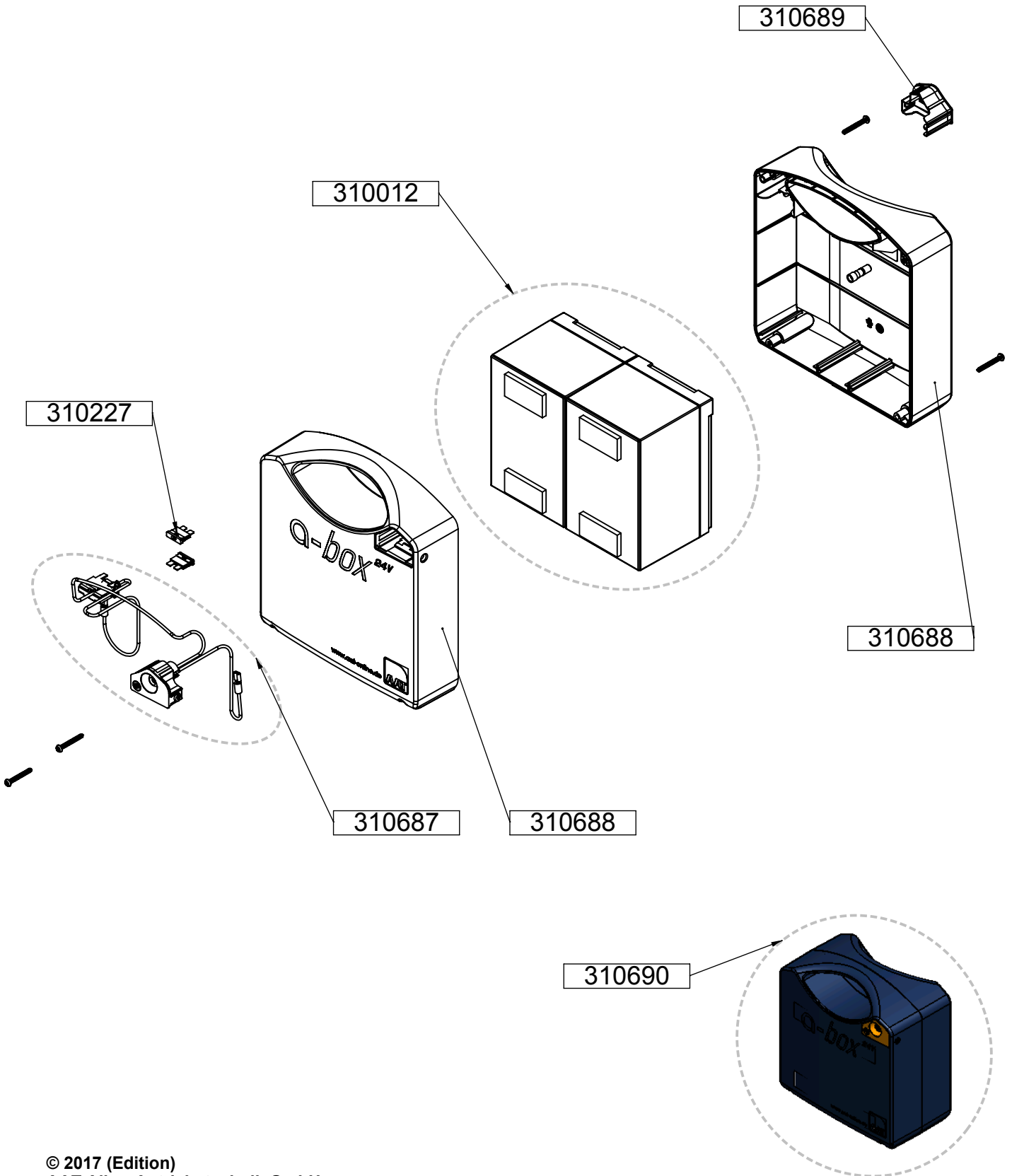

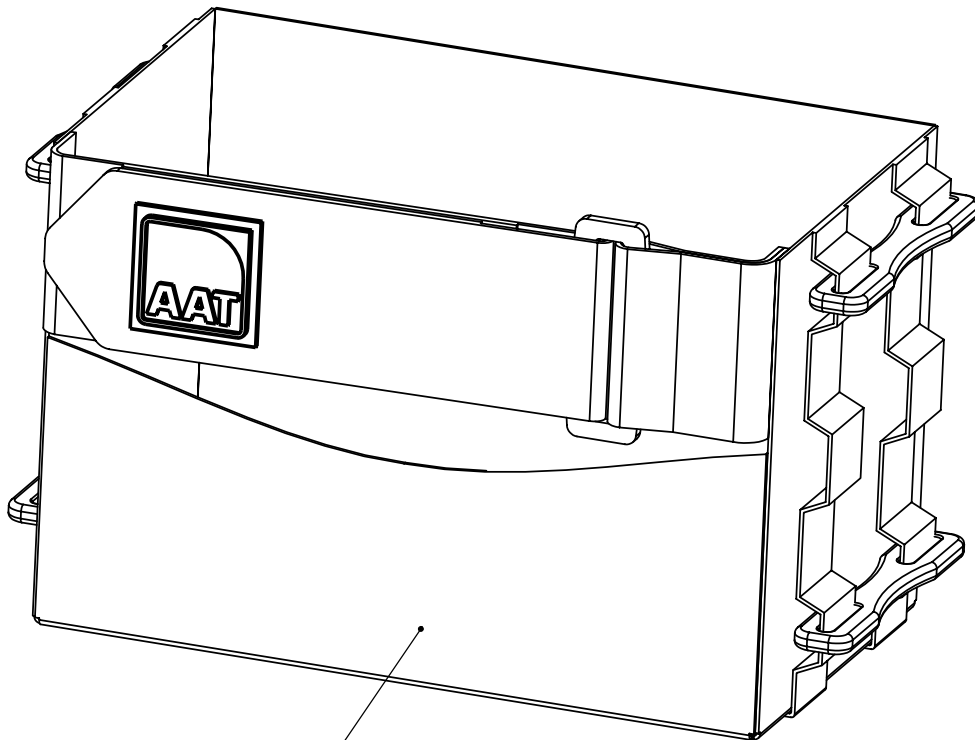

310 007

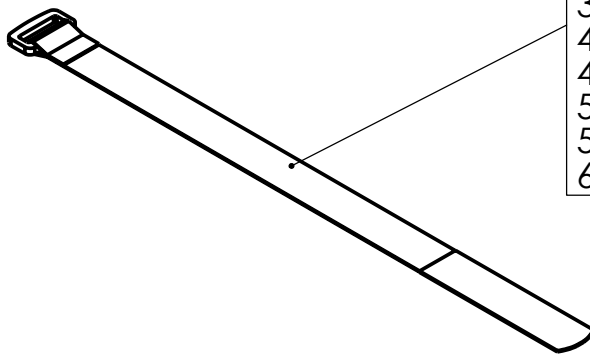

200mm	310 115
250mm	310 116
300mm	310 117
350mm	310 118
400mm	310 119
450mm	310 120
500mm	310 121
550mm	310 122
600mm	310 123

